



Curiamo il vostro lavoro  
The perfect tools for a healthy business

# LUMEN

è l'unità di misura del flusso luminoso **EMESSA** da una sorgente di luce  
refers to the amount of light that is **radiated** from a light source.  
est la mesure de la quantité de lumière **émise** par une source lumineuse.

# LUX

e' l'unità di misura dell' illuminamento, cioè la quantità di flusso luminoso **RICEVUTO** da una superficie.

refers to the intensity with which a surface is **lit**.

est la mesure de la luminosité, c'est-à-dire la quantité de flux lumineux **reçu** par une surface.



L'illuminamento è legato al flusso luminoso della sorgente (lumen), all' angolo di emissione ( $\alpha$ ) e alla distanza della superficie ( $d$ ).

Le lampade **ZETEK KB90** e **KB110** impiegano led da 5 mm, che hanno un angolo di emissione compreso tra 20° e 30°.

Le lampade **ZETEK KB80** e **KB130** impiegano un led con tecnologia STRIP led, con angolo di emissione 120°.

A pari flusso luminoso emesso e distanza della superficie (50 cm nei dati forniti da Zeca), con un angolo di emissione stretto, si otterrà una superficie illuminata di dimensione ridotte, ma con un maggior illuminamento (valore di lux più alto) con un angolo di emissione largo, si otterrà una superficie illuminata di dimensioni più ampie, ma con un minor illuminamento.

The Lighting is related to the luminous flux of the source (lumen), on the beam angle of the light ( $\alpha$ ) and on the distance from the surface ( $d$ ).

The **ZETEK** lamps **KB90** and **KB110** use 5 mm led, which have a beam angle between 20° and 30°.

The **ZETEK** lamps **KB80** and **KB130** use a Led with STRIP led technology, with beam angle of 120°.

At equal luminous flux and distance from the surface (50 cm in the data provided by Zeca), with close beam angle, you'll obtain a smaller illuminated surface, but with a higher lighting (higher lux value).

With a wide beam angle, you'll obtain a larger illuminated surface, but with smaller lighting.

L' éclairage est lié au flux lumineux de la source (lumen), à l'angle de rayonnement ( $\alpha$ ) et la distance de la surface ( $d$ ).

Les baladeuses **ZETEK KB90** et **KB110** utilisent led de 5mm, qui ont un angle de rayonnement compris entre 20° et 30°.

Les baladeuses **ZETEK KB80** et **KB130** utilise un led avec technologie STRIP led avec un angle de rayonnement de 120°.

A' flux lumineux émis et distance de la surce (50 cm selon les données fournis par Zeca) égales, avec un angle de rayonnement étroit, on obtien une surface éclairée de dimensions réduites, mais avec une plus grande intensité lumineuse (valeur de lux élevée), avec un angle de rayonnement large, on obtien une surface éclairée de dimensions plus grandes, mais avec une intensité lumineuse inférieure.



## ANGOLO DI EMISSIONE STRETTO:

**Superficie illuminata di ridotte dimensioni = Illuminamento (lux) più elevato.**

CLOSE BEAM ANGLE:

Smaller illuminated surface = Higher lighting (lux).

ANGLE DE RAYONNEMENT ÉTROIT:

Surface éclairée de dimensions réduites = Intensité lumineuse (lux) plus élevée.



## ANGOLO DI ILLUMINAMENTO AMPIO:

**Superficie illuminata di dimensioni ampie = Illuminamento (lux) più basso.**

WIDE BEAM ANGLE:

Larger illuminated surface = Smaller lighting (lux).

ANGLE DE RAYONNEMENT LARGE:

Surface éclairée de dimensions grandes = Intensité lumineuse (lux) inférieure.

# Lamps



**ZETEK** By **ZEGA**

Art. **KB110**

# KB110

## LAMPADA RICARICABILE A LED

RECHARGEABLE LED LAMP  
LAMPE RECHARGEABLE À LED



▲ **Led indicatore di carica**  
LED charge indicator  
Indicateur de charge à LED



▲ **4 Led - 15 ore di luce**  
4 Led - 15 hours active life  
4 Led - 15 heures d'autonomie

▲ **Calotta trasparente sostituibile**  
Replaceable transparent cover  
Calotte transparente remplaçable

▲ **22 Led - 4 ore di luce**  
22 Led - 4 hours active life  
22 Led - 4 heures d'autonomie

▲ **Interruttore**  
Switch  
Interrupteur

▲ **Corpo pieghevole**  
Adjustable body  
Corps pliable

**22+4  
LED**

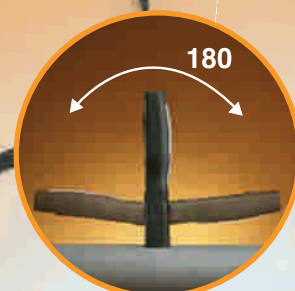

mm 185x290x55  
500 g



**Laccio di sicurezza**  
Safety leash  
Lacet de sécurité



**Base magnetica**  
Magnetic base  
Base aimantée



**2 Ganci**  
2 Hooks  
2 Crochets

<b>Fonte di luce</b>	22x 5mm LED
Light source/Source de lumière/Lichtquelle	
<b>Fonte di luce (spot)</b>	4x 5mm LED
Light source (spot)/Source de lumière (spot)/Lichtquelle (spot)	
<b>Intensità di luce</b>	750 lux @ 50cm
Light intensity/Intensité lumineuse/Lichtintensität	
<b>Flusso luminoso</b>	75lm
Luminous Flux/Flux lumineux/Lichtstrom	



**100/240 V**

**completa di 2 caricatori**  
complete with 2 chargers  
complète avec 2 chargeurs

**Circa 2,5 ore di ricarica**  
Recharge time: approx 2,5 hours  
Temps de recharge: approx. 2,5 heures



**12/24V c.c.**

ATTENZIONE: I caricatori delle varie lampade **NON** sono intercambiabili.  
CAUTION: The chargers of different lamps are **NOT** interchangeable.  
ATTENTION: Les chargeurs des différents baladeuses **NE** sont **PAS** interchangeables.

ATTENZIONE: non lasciare in carica per più di 24 ore!  
CAUTION: Don't exceed 24 h. recharge time!  
ATTENTION: Ne pas dépasser 24 h. en recharge!

ART.	RICAMBI	SPARE PARTS	PIÈCES DE RECHANGE
KB110.050	Calotta trasparente	Transparent cover	Calotte transparente

Art. **KB130**

# KB130

**LAMPADA RICARICABILE SMD LED**  
**POTENTE, COMPATTA, VERSATILE**

**RECHARGEABLE LED LAMP**  
**LAMPE RECHARGEABLE À LED**

▲ **Gancio orientabile**  
Rotating hook  
Crochet orientable

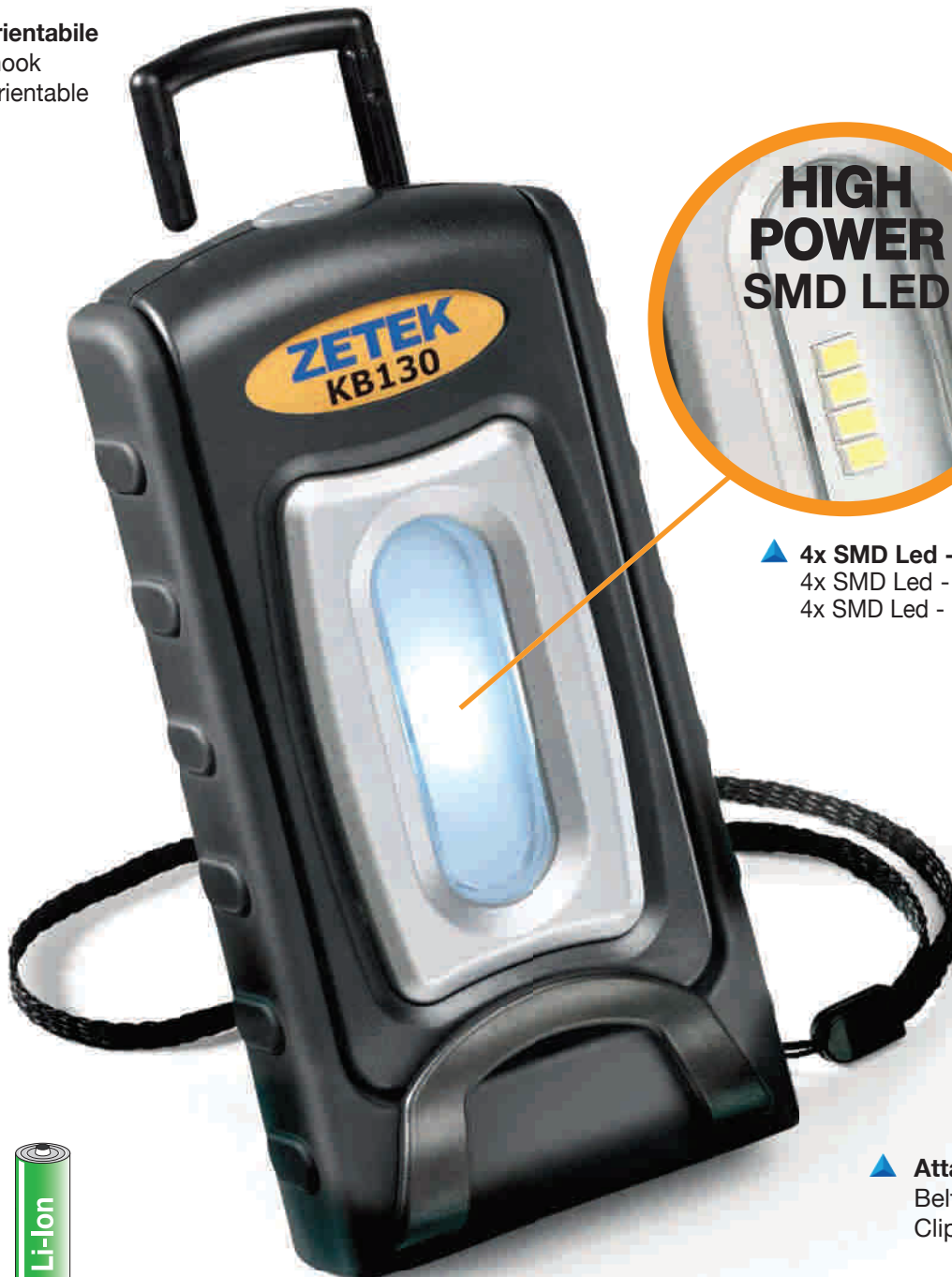

▲ **4x SMD Led - 2 ore di luce**  
4x SMD Led - 2 hours active life  
4x SMD Led - 2 heures d'autonomie

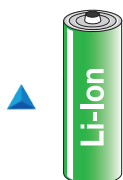

▲ **Attacco per cintura**  
Belt clip  
Clip ceinture

▲ **Corpo pieghevole**  
Adjustable body  
Corps pliable





**Laccio di sicurezza**  
Safety leash  
Lacet de sécurité



**Base magnetica**  
Magnetic base  
Base aimantée



**Attacco per cintura**  
Belt clip  
Clip ceinture



**Base magnetica**  
Magnetic base  
Base aimantée

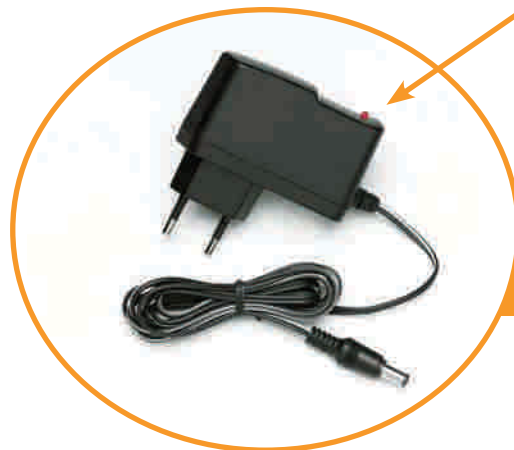

**Indicatore di ricarica**  
Charge indicator  
Indicateur de charge

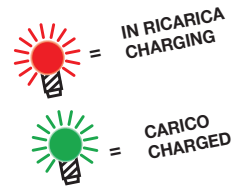

**100/240 V**

**Circa 4 ore di ricarica**  
Recharge time: approx 4 hours  
Temps de recharge: approx. 4 heures

<b>Fonte di luce</b> Light source/Source de lumière Lichtquelle	4x SMD LED
<b>Intensità di luce</b> Light intensity/Intensité lumineuse/Lichtintensität	300 lux @ 50cm
<b>Flusso luminoso</b> Luminous Flux/Flux lumineux Lichtstrom	150lm

ATTENZIONE: I caricatori delle varie lampade **NON** sono intercambiabili.  
CAUTION: The chargers of different lamps are **NOT** interchangeable.  
ATTENTION: Les chargeurs des différents baladeuses **NE** sont **PAS** interchangeables.

ATTENZIONE: non lasciare in carica per più di 24 ore!  
CAUTION: Don't exceed 24 h. recharge time!  
ATTENTION: Ne pas dépasser 24 h. en recharge!

Art. **KB080**

# KB080

## LAMPADA STILO RICARICABILE A LED

RECHARGEABLE LED LAMP  
LAMPE RECHARGEABLE À LED

### SMD LED



- ▲ 7x SMD Led - 4 ore di luce
- 7x SMD Led - 4 hours active life
- 7x SMD Led - 4 heures d'autonomie



▲ Clip



<b>Fonte di luce</b> Light source/Source de lumière Lichtquelle	7x SMD LED
<b>Intensità di luce</b> Light intensity/Intensité lumineuse/Lichtintensität	145 lux @ 50cm
<b>Flusso luminoso</b> Luminous Flux/Flux lumineux Lichtstrom	50lm

**Indicatore di ricarica**  
Charge indicator  
Indicateur de charge

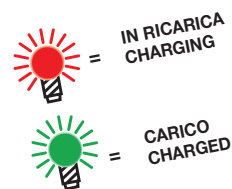
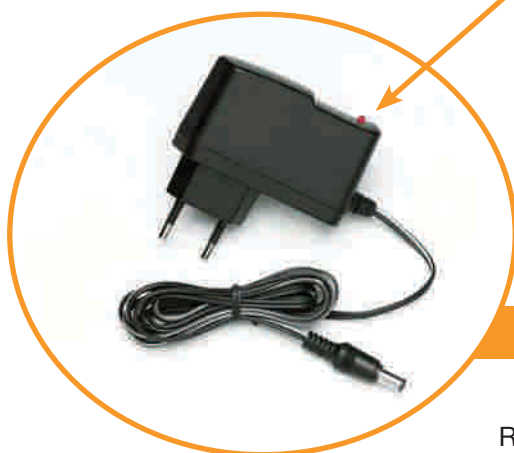

100/240 V

**Circa 4 ore di ricarica**  
Recharge time: approx 4 hours  
Temps de recharge: approx. 4 heures

ATTENZIONE: I caricatori delle varie lampade **NON** sono intercambiabili.  
CAUTION: The chargers of different lamps are **NOT** interchangeable.  
ATTENTION: Les chargeurs des différents baladeuses **NE** sont **PAS** interchangeables.

ATTENZIONE: non lasciare in carica per più di 24 ore!  
CAUTION: Don't exceed 24 h. recharge time!  
ATTENTION: Ne pas dépasser 24 h. en recharge!

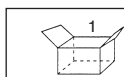

mm 115x180x30  
350 g





Art. **KB90**

# POCKET lamp

LAMPADA RICARICABILE A LED

RECHARGEABLE LED LAMP  
LAMPE RECHARGEABLE À LED

▲ 3 Led - 20 ore di luce  
3 Led - 20 hours active life  
3 Led - 20 heures d'autonomie

▲ 15 Led - 5 ore di luce  
15 Led - 5 hours active life  
15 Led - 5 heures d'autonomie



▲ Base magnetica  
Magnetic base  
Base aimantée



▲ Gancio orientabile  
Rotating hook  
Crochet orientable

▲ Interruttore  
Switch  
Interrupteur

▲ Corpo pieghevole  
Adjustable body  
Corps pliable



170 mm

**15+3  
LED**



Completa di 2 caricatori  
complete with 2 chargers  
Complète avec 2 chargeurs

100/240 V

Circa 5 ore di ricarica  
Recharge time: approx 5 hours  
Temps de recharge: approx. 5 heures



12/24V c.c.

ATTENZIONE: I caricatori delle varie lampade **NON** sono intercambiabili.  
CAUTION: The chargers of different lamps are **NOT** interchangeable.  
ATTENTION: Les chargeurs des différents baladeuses **NE** sont **PAS** interchangeables.

ATTENZIONE: non lasciare in carica per più di 24 ore!  
CAUTION: Don't exceed 24 h. recharge time!  
ATTENTION: Ne pas dépasser 24 h. en recharge!

	mm 202x166x43 360 g
	mm 385x370x265 9,5 kg

Art. **KB055**

# KB055



## LAMPADA FRONTALE ZOOM

ZOOM HEAD LAMP  
LAMPE DE TÊTE ZOOM



Fonte di luce	
Light source/Source de lumière Lichtquelle	3W 250 lumen
Intensità di luce	
MAX POWER	843 lux @ 50cm 10000 lux @ 50cm
ENERGY SAVING	190 lux @ 50cm 2100 lux @ 50cm

Alimentazione	3 x 1.5V	<b>NON FORNITE</b>
Power supply	AAA battery	<b>NOT INCLUDED</b>



	mm 90x90x60 120 g
	mm 380x260x110 2,0 kg

NON FORNITE  
NOT INCLUDED

Art. **KB056**

# KB056

LAMPADA FRONTALE

HEAD LAMP  
LAMPE DE TÊTE



### Fonte di luce

Light source/Source de lumière  
Lichtquelle

2W + 0,5W

### Intensità di luce

MAX POWER

5700 lux @ 50cm

ENERGY SAVING

2200 lux @ 50cm

Alimentazione

3 x 1.5V

NON FORNITE

Power supply

AAA battery

NOT INCLUDED



NON FORNITE  
NOT INCLUDED

	mm 90x90x60 70 g
	mm 380x260x110 1,2 kg

Art. **KS30/230**

▲ Interruttore  
Switch  
Interrupteur

**NEON 30 W**

**IP 55**



## LAMPADA SOTTOCOFANO

**leggera, robusta, potente.**

Lampada trasportabile per illuminazione di vani motore, abitacoli auto e camion, ecc.

- Neon potenza 30 W, con interruttore
- 5 mt. cavo HO5 RN-F
- Fissaggio telescopico da 110 a 180 cm.
- Struttura in alluminio, robustezza e leggerezza



Art. **KS30/230** 230V 30 W

## UNDERHOOD LAMP:

**light, strong, powerful.**

Lamp for the lighting of engine compartments, car and driver's cabins, etc.

- Neon power 30W, with switch
- 5 m. cable HO5 RN-F
- Directional fixing from 110 to 180 cm.
- Aluminium structure, strongness and lightness

Art. **KS30/230** 230V 30 W

## LAMPE D'ÉCLAIRAGE:

**légère, robuste, puissante.**

Lampe pour l'éclairage des compartiments moteur, habitacles de voitures et camions, etc.

- Puissance du neon 30W, avec interrupteur
- 5 m . de cable HO5 RN-F
- Fixation télescopique de 110 à 180 cm.
- Structure en aluminium, robustesse et légèresse

CE □ F IP 55

**Fissaggio telescopico da 110 a 180 cm.**

Directional fixing from 110 to 180 cm.  
Fixation télescopique de 110 à 180 cm.

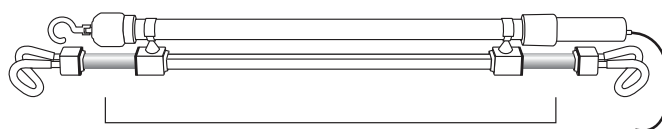

**110 cm min**

**180 cm max**

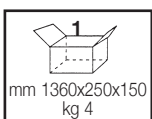

mm 1360x250x150  
kg 4

ART.	RICAMBI	SPARE PARTS	PIÈCES DE RECHANGE
KS30.010	Tubo al neon	Fluorescent tube	Tube fluorescent

# Art. KL230G38



1 Presa  
schuko  
  
MAX 1,5  
Kw Tot.  
  
230V

1 Schuko  
socket  
  
MAX 1,5  
Kw Tot.  
  
230V

## 230V 50Hz 38 W

5 mt. cavo HO7 RN-F  
+ spina schuko

IP 54

Guscio in gomma

Coque en caoutchouc

5 mt. HO7 RN-F  
cable + Schuko plug

IP 54

Rubber boot



# Art. KA000G01

Supporto telescopico,  
con sistema di aggancio  
rapido della lampada

Support telescopique,  
avec système  
d'accrochage rapide  
de la lampe

H: 90 cm. ÷ 250 cm.

Adjustable base,  
with quick lamp  
hooking system

ART.	RICAMBI	SPARE PARTS	PIÈCES DE RECHANGE
KS000N38	Tubo al neon	Fluorescent tube	Tube fluorescent
KS000G38	Protezione trasparente	Transparent protection	Protection transparente

# TORCIA A LED

## LED FLASHLIGHT

- Sorgente luminosa: ultra light power led.  
Sono garantiti per 100.000 ore di funzionamento, che equivalgono a 60 anni, con un uso quotidiano di 5 ore.
- Interruttore protetto, soft touch.
- Light source: ultra light power LEDs  
The lifetime of the LEDs is up to 100.000 hours, which is equivalent to 60 years with 5 hours' daily use.
- Soft touch protected switch.
- Source lumineuse: ultra light power led.  
La durée est garantie pour 100.000 heures de fonctionnement, qui correspond à 60 années, avec un usage quotidien de 5 heures.
- Interrupteur protégé, soft touch.



Art. **KB010**

Q.tà minima:  
Minimum order:  
10 pz.

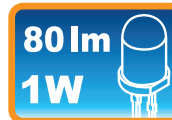
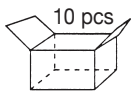

NON FORNITE  
NOT INCLUDED

Art. **KB020**



Q.tà minima:  
Minimum order:  
10 pz.

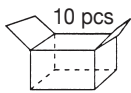

NON FORNITE  
NOT INCLUDED

Art. **KLN/230**

## LAMPADA FLUO 11W

▲ **IP55**

5 mt. cavo H05 RN-F  
5 m. cable H05 RN-F  
5 m. cable H05 RN-F

▲ **Gancio orientabile**  
Rotating hook  
Crochet orientable



▲ **Calotta trasparente sostituibile**  
Replaceable transparent cover  
Calotte transparente remplaçable

ART.	RICAMBI	SPARE PARTS	PIÈCES DE RECHANGE
KS000N11	Tubo al neon	Fluorescent tube	Tube fluorescent
KLN.010	Calotta trasparente	Transparent cover	Calotte transparente



Q.tà minima:  
Minimum order:  
15 pz.

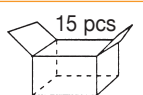

# video endoscope



**ZETEK** By **ZEGA**

Art. **KE700**

# KE700

## VIDEO ENDOSCOPIO

**VIDEO ENDOSCOPE**  
**ENDOSCOPE VIDÉO**

▲ **Display a colori**  
**alta risoluzione**  
Colour display:  
high resolution

**CAPACITÀ  
DI MEMORIA INTERNA**  
Internal memory capacity

**500** immagini  
pictures

**SD CARD MAX 32 GB** ▲  
(NON inclusa - NOT included)

▲ 1 mt



▲ **Ø 6 mm - con luce interna**  
**Ø 6 mm - with internal light**



<b>Display a colori:</b>	3,2" TFT LCD	
Colour display:	320 x 240	
<b>Sensore CCD</b>	1/4" CMOS	
CCD Sensor	320 x 240	
<b>Diametro Sonda standard</b>	6 mm	
Standard Probe Diameter		
<b>Lunghezza sonda</b>	1 m	
Probe length		
<b>Formato immagini</b>	JPG (640 x 480)	
Picture format		
<b>Formato video</b>	3GP 30fps	
Video format		
<b>Dimensione massima scheda SD</b>	NON INCLUSA	32Gb
SD card max size	NOT INCLUDED	
<b>Capacità memoria interna</b>	500 immagini	
Internal memory capacity	500 pictures	
<b>Batteria interna</b>	3,7V 2000mAh	
Internal battery	Li-Ion	

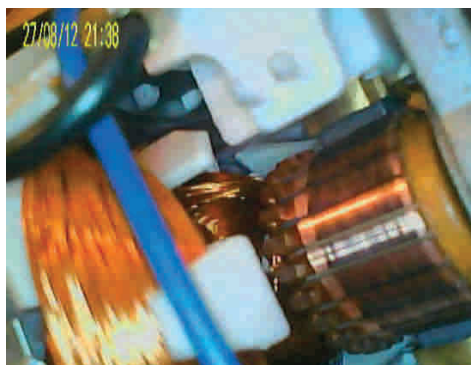

**KE700 - Contenuto confezione:**

Endoscopio  
 Sonda flessibile Ø 6mm  
 Magnete, Gancio, Specchio  
 Manuale di istruzioni  
 Batteria ricaricabile Li-Ion 3,7V  
 Alimentatore USB 100-240V  
 Cavo USB  
 Valigetta







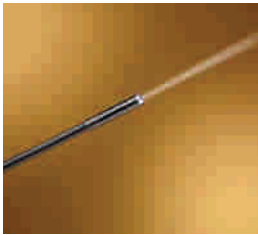

**KE700 - Package contents:**

Endoscope  
 Ø 6mm flexible probe  
 Magnet, Hook, Mirror  
 Instruction Manual  
 Rechargeable 3,7V Li-Ion battery  
 USB 100-240V Power supply  
 USB cable  
 Carrying case

**KE700 - Contenu du paquet:**

Endoscope  
 Sonde flexible Ø 6mm  
 Aimant, crochet, miroir  
 Manuel d'instruction  
 Batterie rechargeable Li-Ion 3,7V  
 Adaptateur USB 100-240V  
 Cable USB  
 Mallet

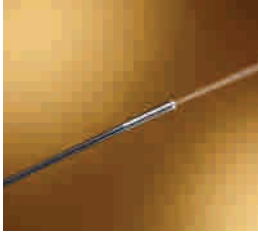

ART.	RICAMBI	SPARE PARTS	PIÈCES DE RECHANGE
KE700/6	 <p>Sonda Ø 6mm            Lunghezza 1 mt            Include magnete,            gancio e specchio</p> 	<p>Ø 6mm probe            Length 1 mt            Including Magnet,            hook, mirror</p> 	<p>Sonde Ø 6mm            Longueur 1 mt            Comprend aimant,            crochet, miroir</p> 
ART.	ACCESSORI	ACCESSORIES	ACCESSOIRES
KE700/17	 <p>Sonda Ø 17mm            Lunghezza 1 mt            Include magnete,            gancio e specchio</p> 	<p>Ø 17mm probe            Length 1 mt            Including Magnet,            hook, mirror</p> 	<p>Sonde Ø 17mm            Longueur 1 mt            Comprend aimant,            crochet, miroir</p> 
KE700/EXT3	 <p>prolunga 3 mt.            per sonda 17mm</p>	<p>3 m. extension            for probe            17mm</p>	<p>rallonge de 3 m.            pour sonde            17mm</p>
KE700/4	 <p>Sonda Ø 4,5mm            Lunghezza 1 mt</p>	<p>Ø 4,5mm probe            Length 1 mt</p>	<p>Sonde Ø 4,5mm            Longueur 1 mt</p>

# Testers



**ZETEK** By **ZEGA**

Art. **KM010**

# MULTIMETRO a penna

PEN TYPE MULTIMETER



## MULTIMETRO A PENNA

### ▲ Puntale a scomparsa

Retractable test lead



Multimetro 'a penna' molto leggero e versatile per lavorare in posizioni scomode e in luoghi poco accessibili dove non sarebbe possibile operare con uno strumento tradizionale.

Viene fornito di serie con puntale e pinzetta per lavorare ancora più comodamente con una mano completamente libera.

Esegue le seguenti misure:

- Tensione (AC/DC) fino a 600V
- Corrente (AC/DC) fino a 0,2A, adatto quindi a piccoli carichi come spie del cruscotto o led
- Resistenza
- Prova continuità con segnale sonoro
- Prova Diodi
- Test livello logico (alto basso) con led di segnalazione, per verificare immediatamente se un punto è sotto tensione o no, molto utile sulle autovetture.
- Autoranging, selezione automatica della scala di misura
- Data Hold, blocco del valore sul display
- Misura valore massimo
- Autospegnimento
- Fornito con pratica custodia

Display LCD 20mm

Max Voltage 600V AC/DC

Tensione DC DC Voltage	200mV, 2V, 20V, 200V, 600V
Tensione AC AC Voltage	200mV, 2V, 20V, 200V, 600V
Corrente DC DC Current	20mA, 200mA
Corrente AC AC Current	20mA, 200mA
Resistenza Resistance	200Ω, 2kΩ, 20kΩ, 200kΩ, 2MΩ, 20MΩ
Continuità Continuity	●    R < 50Ω
Prova Diodi Diode Test	▶ +
Test Logico Logic Test	0-1.5V=Rosso/Red 3.5-5V=Verde/Green

Blocco del valore Valore massimo	Data Hold Max Hold
-------------------------------------	-----------------------

Autospegnimento Auto power off	15 min
-----------------------------------	--------

Alimentazione Power supply	2 x 1,5V AAA battery	NON FORNITE NOT INCLUDED
-------------------------------	-------------------------	-----------------------------

IEC EN 61010-1  
CAT. III 600V



ART.	RICAMBI	SPARE PARTS	PIÈCES DE RECHANGE
<b>KM010.010</b>	Kit puntali	Probes	Jeu de cordons

Art. **KM020**



# MULTIMETRO

## digitale autoranging

**AUTORANGING DIGITAL MULTIMETER**

### MULTIMETRO DIGITALE



Multimetro Digitale Autoranging  
Digital Autoranging Multimeter

Tensione DC DC Voltage	200mV, 2V, 20V, 200V, 600V
Tensione AC AC Voltage	200mV, 2V, 20V, 200V, 600V
Corrente DC DC Current	200µA, 2mA, 20mA, 200mA, 2A, 10A
Corrente AC AC Current	200µA, 2mA, 20mA, 200mA, 2A, 10A
Resistenza Resistance	200Ω, 2kΩ, 20kΩ, 200kΩ, 2MΩ, 20MΩ
Continuità Continuity	●    R < 50Ω
Prova Diodi Diode Test	▶ +
Batterie Battery Test	1.5V, 3V, 9V
Temperatura Temperature	-20 + 1000 °C 0 + 1800 °F
Transistor Transistor	hFE 0 – 1000

Tensione Massima Max Voltage	600V AC/DC
---------------------------------	------------

Blocco del valore Valore massimo	Data Hold Max Hold
-------------------------------------	-----------------------

Autospegnimento Auto power off	15 min
-----------------------------------	--------

Alimentazione Power supply	3 x 1.5V AAA battery	NON FORNITE NOT INCLUDED
-------------------------------	-------------------------	-----------------------------

Multimetro adatto alla maggior parte dei lavori.

Esegue le seguenti misure:

- Tensione (AC/DC) fino a 600V
- Corrente (AC/DC) fino a 10A, adatto per controllare utenze di una certa importanza (fino a 2300W a 230V). Protetto da fusibile interno.
- Resistenza
- Prova Diodi
- Prova Continuità con indicazione acustica
- Prova transistor (con adattatore fornito)
- Temperatura (-20°C/+1000°C) con termocoppia fornita.
- Test batterie (1.5V - 3V - 9V)
- Autoranging, selezione automatica della scala di misura
- Data Hold, blocco del valore sul display
- Misura valore massimo
- Autospegnimento
- Retroilluminazione del display.

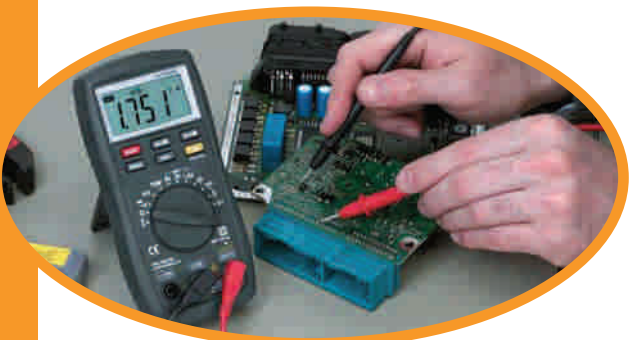

IEC EN 61010-1  
CAT. III 600V



ART.	RICAMBI	SPARE PARTS	PIÈCES DE RECHANGE
<b>KM030.010</b>	Kit puntali	Probes	Jeu de cordons
<b>KM030.015</b>	Termocoppia	Termocouple	Thermocouple

Art. KM030

# MULTIMETRO universale

ALL-PURPOSE MULTIMETER

## MISURA ANCHE

- ◆ Temperatura (-20°C/+1000°C)
- ◆ Luminosità (lux)
- ◆ Intensità sonora (dB, decibel)
- ◆ Temperatura e umidità ambiente

## IT CAN ALSO MEASURE

- ◆ Temperature (-20°C/+1000°C)
- ◆ Brightness (lux)
- ◆ Sound intensity (dB, decibel)
- ◆ Environment temperature and humidity

## MESURE EGALEMENT

- ◆ Température (-20°C/+1000°C)
- ◆ Luminosité (lux)
- ◆ Intensité sonore (dB, decibel)
- ◆ Température et humidité d'ambiant

## KANN AUCH GEMESSEN WERDEN

- ◆ Temperatur (-20°C/+1000°C)
- ◆ Leuchtkraft (lux)
- ◆ Lautstärke (dB, decibel)
- ◆ Umgebungs- Temperatur und -Feuchtigkeit

## MEDIDA TAMBIEN

- ◆ Temperatura (-20°C/+1000°C)
- ◆ Luminosidad (lux)
- ◆ Intensidad sonora (dB, decibel)
- ◆ Temperatura y humedad de ambiente

## MULTIMETRO UNIVERSALE



▲ Indicazione luminosa della connessione da utilizzare

Light shows which connection to use



Multimetro Universale professionale in grado di eseguire molte misure che non sono possibili con strumenti tradizionali. Tramite dei led all'interno delle bocche di connessione indica quali utilizzare per la misura impostata e avverte in caso di errore.

Esegue le seguenti misure:

- Tensione (AC/DC) fino a 750V
- Corrente (AC/DC) fino a 10A, adatto per controllare utenze di una certa importanza (fino a 2300W a 230V). Protetto da fusibile interno.
- Resistenza
- Prova Diodi
- Prova Continuità con indicazione acustica
- Temperatura (-20°C/+1000°C) con termocoppia fornita.
- Temperatura e umidità ambiente con sensori interni.
- Capacità (condensatori)
- Frequenza e Duty cycle
- Luminosità (lux)
- Intensità sonora (dB, decibel)
- Autoranging, selezione automatica della scala di misura
- Data Hold, blocco del valore sul display
- Autospegnimento
- Retroilluminazione del display.



## Display LCD 16mm con retro-illuminazione 16mm High LCD display with backlight

Tensione DC DC Voltage	400mV, 4V, 40V, 400V, 750V
Tensione AC AC Voltage	400mV, 4V, 40V, 400V, 750V
Corrente DC DC Current	400µA, 4mA, 40mA, 400mA, 4A, 10A
Corrente AC AC Current	400µA, 4mA, 40mA, 400mA, 4A, 10A
Frequenza Frequency	10Hz, 100Hz, 1kHz, 10kHz, 100kHz
Duty Cycle Duty Cycle	0.1 – 99.9%
Resistenza Resistance	400Ω, 4kΩ, 40kΩ, 400kΩ, 4MΩ, 40MΩ
Lux Lux	4000 – 40000 Lux
Capacità Capacity	40nF – 100µF
dB dB	40 – 100dB
Umidità RH RH Humidity	20 – 95%
Continuità Continuity	●    R < 40Ω

Tensione Massima Max Voltage	1000V AC/DC
---------------------------------	-------------

Blocco del valore Valore massimo	Data Hold Max Hold
-------------------------------------	-----------------------

Autospegnimento Auto power off	30 min
-----------------------------------	--------

Diodi Diode Test	➤
---------------------	---

Temperatura Temperature	-20 + 1000 °C 0 + 1800 °F	Termocoppia Termocouple
Temperatura Temperature	-20 +40 °C 0 +100 °F	Sensore interno Internal sensor

Alimentazione Power supply	3 x 1.5V AAA battery	NON FORNITE NOT INCLUDED
-------------------------------	-------------------------	-----------------------------

IEC EN 61010-1  
CAT. III 600V



ART.	RICAMBI	SPARE PARTS	PIÈCES DE RECHANGE
KM030.010	Kit puntali	Probes	Jeu de cordons
KM030.015	Termocoppia	Termocouple	Thermocouple

Art. **KM040**

# MULTIMETRO a pinza

CLAMP TYPE MULTIMETER

## MULTIMETRO A PINZA

▲ **Pinza illuminata**  
Lighted clamp





Pinza amperometrica / Multimetro. Questo strumento permette di eseguire le misure di corrente (fino a 1000A) senza scollegare l'utenza. Permette comunque di eseguire tutte le misure di un normale multimetro:

- Tensione (DC/AC) fino a 700V
- Corrente (AC/DC) fino a 1000A dalla pinza
- Resistenza
- Prova Diodi
- Prova Continuità con indicazione acustica
- Frequenza sia dai puntali che dalla pinza
- Retroilluminazione e illuminazione della pinza
- Indicazione numerica e a barra 42 segmenti
- Autoranging
- Data Hold e Misura valore massimo
- Autospegnimento
- Fornito con pratica custodia



## Display LCD 16mm con retro-illuminazione 16mm High LCD display with backlight

Tensione DC DC Voltage	4V, 40V, 400V 600V, 1000V
Tensione AC AC Voltage	4V, 40V, 400V 600V, 700V
Corrente DC DC Current	400A, 600A, 1000A
Corrente AC AC Current	400A, 600A, 1000A
Resistenza Resistance	400Ω, 4kΩ, 40kΩ, 400kΩ, 4MΩ, 40MΩ
Duty Cycle Duty Cycle	0.1 – 99.9%
Resistenza Resistance	400Ω, 4kΩ, 40kΩ, 400kΩ, 4MΩ, 40MΩ
Continuità Continuity	●  ) R < 50Ω
Prova Diodi Diode Test	▶+

Frequenza Frequency	40Hz, 400Hz, 4kHz, 40kHz, 100kHz
Frequenza Frequency	40Hz, 400Hz
Continuità Continuity	● R < 40Ω

Tensione Massima Max Voltage	600V AC/DC
---------------------------------	------------

Blocco del valore Valore massimo	Data Hold Max Hold
-------------------------------------	-----------------------

Autospegnimento Auto power off	30 min
-----------------------------------	--------

Alimentazione Power supply	3 x 1.5V AAA battery	NON FORNITE NOT INCLUDED
-------------------------------	-------------------------	-----------------------------

IEC EN 61010-1 e IEC EN 61010-2-032  
CAT. III 600V



ART.	RICAMBI	SPARE PARTS	PIÈCES DE RECHANGE
KM030.010	Kit puntali	Probes	Jeu de cordons

Art. **KM041**

# PINZA AMPEROMETRICA di precisione

**HIGH ACCURACY CLAMP METER**

▲ **Luce**  
light



Pinza amperometrica specifica per misure precise di bassi valore di corrente. Ideale per misurare correnti di dispersione o assorbimenti su autovetture, senza dover disconnettere il carico. La pinza è dotata di una utile funzione torcia per lavorare in zone buie. Le ridotte dimensioni ne permettono l'uso in zone di scarsa accessibilità. Il display LCD di grandi dimensioni e con retroilluminazione a led facilita la lettura.

- Display LCD con retroilluminazione
- Funzione torcia con led bianco ad alta luminosità
- Funzione HOLD
- Funzione azzeramento
- Autospegnimento
- Fornita con pratica custodia

Display con retro-illuminazione  
LCD display with backlight

Corrente A.C.	1mA - 80A	
A.C. Current		
Corrente D.C.	1mA - 80A	
D.C. Current		
Alimentazione	2 x 1,5V	NON FORNITE
Power supply	AAA battery	NOT INCLUDED

**CAT.II 600V - CAT.III 300V**  
**EN 61010-1 - EN 61010-2-032**



Art. **KM075**

# KM075

## DISTANZIOMETRO LASER

LASER DISTANCE METER



Range di misura	0,05m – 50m
Range	0,05m – 50m
Precisione (0 - 10m)	±1.5mm
Accuracy (0 - 10m)	±1.5mm
Precisione (10 – 50m)	±1.5mm/m
Accuracy (10 – 50m)	±1.5mm/m
Unità di misura	m, in, ft, ft+in
Unit	m, in, ft, ft+in
Calcolo area e volumi	✓
Area and volume calculation	✓
Misura indiretta	✓
Indirect measurement	✓

Somme, sottrazioni	✓
Add, subtract	✓
Misura continua	✓
Continuous measurement	✓
Display retroilluminato	✓
Backlight display	✓
Indicazione sonora	✓
Sound indicator	✓
Grado di protezione	IP54
Protection degree	IP54
Memoria misure	20
Measurement storage	20



Alimentazione	2 x 1,5V	NON FORNITE
Power supply	AAA battery	NOT INCLUDED

Art. **KM050**

# AMPEROMETRO 30A per autovetture

30A AUTOMOTIVE CURRENT TESTER



**sonda per fusibili  
a lama**

blade fuse probe

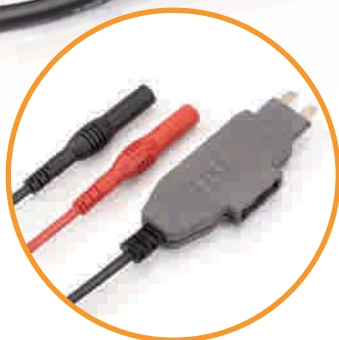

**sonda per fusibili  
a mini-lama**

mini-blade fuse probe

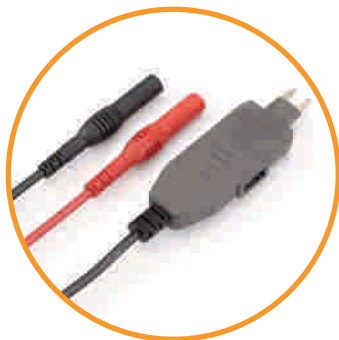

Amperometro specifico per le misure di corrente tramite i fusibili a lama. Lo strumento permette di misurare l'assorbimento degli utilizzatori su un'autovettura direttamente dalla scatola fusibili. E' dotato di sonde per fusibili "a lama" e "mini lama". Il display visualizza l'assorbimento sia tramite valore numerico che tramite indicatore a barra analogico.

- Display LCD con indicatore analogico a barra
- Funzione HOLD
- Funzione azzeramento
- Fornito con sonde per fusibili "a lama" e "mini lama"

<b>Campo di misura</b> Range	0.1 - 30A	
<b>Alimentazione</b> Power supply	1 x 9V battery	<b>NON FORNITA</b> NOT INCLUDED



ART.	RICAMBI	SPARE PARTS	PIÈCES DE RECHANGE
<b>KM050.010</b>	Sonda per fusibili Mini Lama	Mini-blade fuse probe	Sonde pour fusibles lame mini
<b>KM050.020</b>	Sonda per fusibili Lama	Blade fuse probe	Sonde pour fusibles lame

Art. **KM051**

# AMPEROMETRO 80A per autovetture

## 80A AUTOMOTIVE CURRENT TESTER



**adattatore per fusibili  
a maxi lama**  
maxi-blade  
fuse adapters

**adattatore per fusibili  
a lama e mini lama**

blade and mini-blade  
fuse adapters

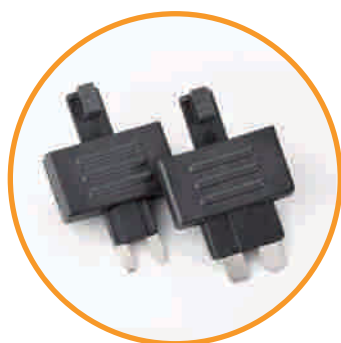

Amperometro specifico per le misure di corrente tramite i fusibili a lama. Lo strumento permette di misurare l'assorbimento degli utilizzatori su un'autovettura direttamente dalla scatola fusibili del vano motore con fusibili "maxi lama". E' dotato di adattatori per fusibili "a lama" e "mini lama". Il display visualizza l'assorbimento sia tramite valore numerico che tramite indicatore a barra analogico. La funzione "Peak Hold" permette di memorizzare picchi di assorbimento.

- Display LCD con indicatore analogico a barra
- Funzione HOLD
- Funzione Peak Hold
- Funzione azzeramento
- Sonda per la misurazione di fusibili "maxi lama"
- Fornito con adattatore per fusibili "a lama" e "mini lama"

<b>Campo di misura</b> Range	0.1 - 80A	
<b>Alimentazione</b> Power supply	1 x 9V battery	<b>NON FORNITA</b> NOT INCLUDED



ART.	RICAMBI	SPARE PARTS	PIÈCES DE RECHANGE
KM051.010	Kit adattatori lama e mini-lama	Blade and mini-blade adapters kit	kit adaptateurs lame et lame mini

Art. **KM060**

# TERMOMETRO a infrarossi

**INFRARED  
THERMOMETER**



**-50 °C  
+500 °C**

**-58 °F  
+932 °F**



Termometro ad infrarossi professionale. Permette di misurare la temperatura di un oggetto, da -50°C a 500°C senza contatto. E' dotato di un puntatore laser per facilitare l'individuazione della zona di misura. La funzione "Hold" automatica mantiene sul display l'ultimo valore di temperatura misurato. Il display retroilluminato facilita la lettura in situazioni di scarsa luminosità.

- Display LCD con retroilluminazione
- Puntatore LASER
- Hold automatico al rilascio del grilletto
- Auto spegnimento
- Fornito con pratica custodia

**CE**

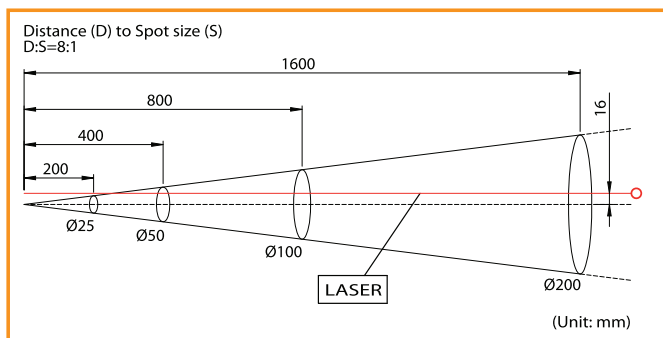

<b>Campo di misura</b>	<b>-50°C +500°C</b>	
<b>Range</b>	<b>-58°F +932°F</b>	
<b>Risoluzione ottica</b>	<b>8:1</b>	
<b>Optical resolution</b>	<b>8:1</b>	
<b>ε (Emissività)</b>	<b>0,95</b>	
<b>ε (Emissivity)</b>	<b>0,95</b>	
<b>Alimentazione</b>	<b>1 x 9V battery</b>	<b>NON FORNITA</b>
<b>Power supply</b>	<b>1 x 9V battery</b>	<b>NOT INCLUDED</b>

Art. **KM070**

# TACHIMETRO

TACHOMETER

**RPM** **m/min**



**adattatore per misure a contatto**

adapter for contact measurement



**3 testine intercambiabili**

3 heads



Tachimetro professionale per la misurazione della velocità di rotazione senza contatto, a riflessione, tramite fascio laser. Tramite l'apposito adattatore in dotazione e le 3 testine intercambiabili è possibile effettuare misure per contatto. Una ulteriore testina permette di effettuare misure di velocità lineari.

Lo strumento memorizza automaticamente l'ultimo valore misurato, il minimo e il massimo.

- Display LCD di elevate dimensioni
- Misura senza contatto tramite fascio laser
- Funzione memoria (ultimo valore, minimo, massimo)
- Fornito con adattatore per misure a contatto, con 3 testine intercambiabili
- Testina per misure di velocità lineari.
- Fornito in pratica custodia protettiva

CE

Velocità di rotazione RPM	5 - 99999 RPM
Velocità lineare Linear speed	0,05 - 1999,9 m/min

Alimentazione Power supply	4 x 1,5V AA battery	NON FORNITE NOT INCLUDED
-------------------------------	------------------------	-----------------------------

ART.	RICAMBI	SPARE PARTS	PIÈCES DE RECHANGE
<b>KM070.010</b>	Adattatore per misure a contatto	Adapters for contact measurement	Adaptateur pour mesures à contact
<b>KM070.020</b>	Set adattatori	Adapters set	Jeu d'adaptateurs



Strada della Chiara, 25  
10080 Feletto Canavese - (Torino) Italy  
Tel. +39 0124 499611  
Fax + 39 0124 490669  
[www.zeca.it](http://www.zeca.it)  
[info@zeca.it](mailto:info@zeca.it)  
[italia@zeca.it](mailto:italia@zeca.it)  
[export@zeca.it](mailto:export@zeca.it)